

# What's Required?



## ELECTRIC

- Dedicated minimum 15 amp/110V circuit

## INTERNET CONNECTIVITY

- Stable cellular or wifi signal (preferred) or hardwired network connection

## SPACE

- 24"D x 34"W x 36"H counter space
- Form-fitting stand available

## WATER

- Cold Water Line. 3/8" or 1/4" Compression End Shut Off Valve within 6' of machine
- 5 gallon water bottle pump available if no water line is available

## COUNTER MODIFICATION OPTIONS

- Countertop cutout for a waste chute (template can be provided upon request)
- If the water shutoff valve is under the counter, then plan for a 3/4" hole
- If the power outlet is under the counter, plan for a 3" diameter hole

# SipWithMe Machine Dimensions

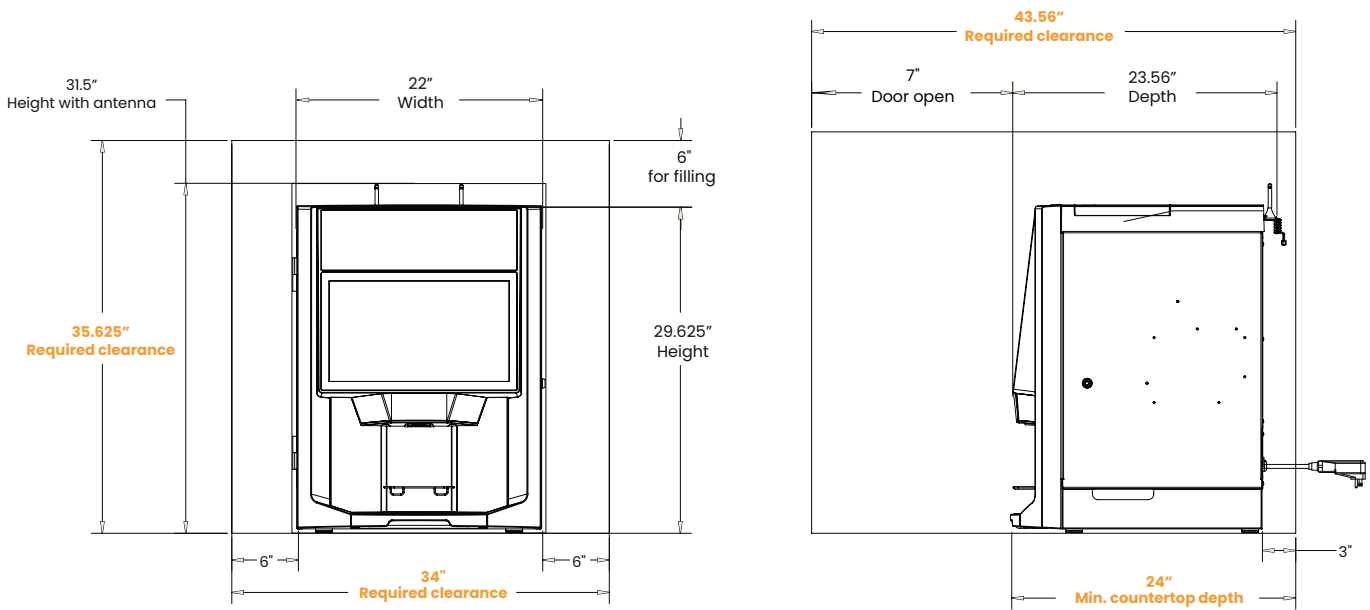

MAX 5 FEET DISTANCE OF ELECTRICAL OUTLET

